

The imperative usage of an innovated Biscuit-Shaped Tenon Groove Machine towards Technology Model for interior design technology program in technical education

Redjie D. Arcadio

Mark Paul Lim

Gerwine J. Medio

Catalino Jimmy B. Pescadero

Joecyn N. Archival

Jon Redgie N. Arcadio

Alan A. Bendanillo

Ramelito C. Almendras

Cebu Technological University- Pinamungajan Campus, Pinamungajan Cebu,
Philippines

Abstract: This study was conducted in order to create and effectively use an Innovated Biscuit-Shaped Tenon Groove Machine towards Technology Model for Interior Design technology program in Technical education so that the creative learners could use it to support instruction in school, the study was conducted at Cebu Technological University- Pinamungajan Campus, Pinamungajan, Cebu. The output of this study was regarded as an alternative technology tool of CTU- Pinamungajan Campus, Pinamungajan, Cebu where the study is being done. This study used quasi-experimental techniques, specifically survey research. 90 students and 5 professors/instructors were given questionnaires to complete for evaluation. Weighted mean and t-test were used to analyze the collected data. Based on the results and following a careful analysis, it is concluded that Innovative Biscuit-Shaped Tenon Groove Machine meets campus needs and standards.

Keywords: innovated Biscuit Tenon Groove Machine, Technology Model, interior design technology, technical education, pinamungajan cebu

INTRODUCTION

Furniture manufacturing industries specifically wood and furnishing products has practicing to use easy and simple hardware's and fasteners. The wooden furniture sector is becoming increasingly competitive, as more and more producers enter the global market (Kaplinsky, Morris & Readman, 2002). Some the workshop section has using the wood joineries such as mortise and tenon joints, tongue and groove joints, butt joint with wooden dowels. The present research provides an improved biscuit jointer which allows a ruler guide to be kept completely level during fine

adjustment of the vertical position and angular orientation of the ruler guide with respect to a ruler and accurately abuts against a work piece (Gibson, 1992). The biscuit jointer of the invention includes: a circular cutter blade; a base accommodating the cutter blade; a housing containing a motor for driving the cutter blade and being slidable relative to the base; a ruler disposed on one end of the base to abut against an end face of a work piece; and a ruler guide vertically slidable along the ruler (Yoshinori Shibata, 1991). The ruler has a vertically extending slide edge plane on a predetermined end thereof, and the ruler guide has a linear guide on the predetermined end thereof, which slides against the slide edge plane. The ruler grade further includes a spur gear engaging with a toothed rack formed on the ruler, which allows vertical movement of the ruler guide along the ruler (Arcadio, et al., 2019). A leaf spring applies pressure against the contact of the linear guide with the slide edge plane to secure the attachment of the ruler guide to the ruler (). The biscuit jointer is further provided with a clamp to restrain the movement of the ruler guide relative to the ruler (Broun, 2018). The present problem encountered during the production of the furniture product is the delayed on making the products because of the machine use and the process. To accelerate the production, the researcher is make the machine innovation to solve the said issues.

The Cebu Technological University, Pinamungajan Campus increased its number of students every year. Supposedly students as well as teachers should have available equipment in their laboratory work and workshops but sad to say this equipment is not available for them. Today, technology is evolving by innovating the available materials even from waste and scraps (Muellers, 1989). From this, the researcher is proposing to make a Biscuit Tenon Groove Machine for the use of the technology students. The innovated Biscuit Tenon Groove Machine has its features: capable to adjust the machine up and down, the depth of the wood slots, the length of the slots and lock with toggle clamp. At this point, the problems are initially answered by assessing the performance of the students, faculty and experts.

Statement of the Problem

This research determines the effectiveness and acceptability of the Innovated Biscuit-Shaped Tenon Groove Machine at Cebu Technological University-Pinamungajan Campus, Pinamungajan Cebu during Academic Year 2020-2021 as basis for technology Model.

Specifically, it seeks answers to the following:

1. What are the prior arts related to biscuit groove machine?
2. What are the technical requirements for development of the mortising machine as to:
 - 2.1. detailed machine plan and features;
 - 2.2. fabrication and installation;

2.3. materials cost; and

2.4. safety?

3. As rated by the respondent-groups, what is the level of effectiveness of the developed wood biscuit-shaped tenon groove machine as to the aforementioned requirements?

4. What are functionality of the innovated biscuit-shaped tenon groove machine?

5. As evaluated by the respondent-groups to what extent is the suitability of the innovated biscuit-shaped tenon groove machine?

6. Based on findings what technology model can be adopted?

Review of Related Literature

The theories was anchored combined models (see Figure 1) as the Theory for the Integration of Educational Technology (TIET) and use the model as a framework for analyzing the reflections made after each teaching session during which technology was used for instruction and the Technology Acceptance Model (TAM) of Fred Davis (1989) which determines the user acceptance of any technology perceived usefulness and perceived ease of use factors (Arcadio et al., 2020). Perceived Usefulness defines as the degree to which an individual believes that using a particular system will enhance the task performance. Perceived Ease of Use defines as the degree to which an individual believes that using a particular system is free of physical and mental effort (Davis, 1989; Davis *et al.*, 1989; Davis, 1993). The TAM suggests that intention to accept technology is determined directly by attitude, perceived usefulness and perceived ease of use. According to TAM individuals' intention to use technology determines the actual use of the application and attitudes toward technology affect the intention (Davis *et al.*, 1989; Davis and Venkatesh, 2004; Venkatesh *et al.*, 2012).

Technology Acceptance Model (TAM) is considered an influential extension of theory of reasoned action (TRA), according to Yousafzai et al. (2010). The TRA is a general model which is concerned with individuals' intended behaviors. According to TRA an individual's performance is determined by the individual's attitude and subjective norms concerning the behavior in question (Hinch, 2002). In addition an individual's beliefs and motivation interact with existing behavior.

Benefits of the community and the University in using the Innovated Biscuit Tenon Groove Machine. It refers to the innovated machine will use during the learning of the respondents.

D.O. 13, OSH-DOLE. It refers to section 13 of DOLE D.O. No. 13 requires that the contractor shall provide continuing construction safety and health training to all technical personnel under his employ. Protective Equipment and Devices of OSHS.

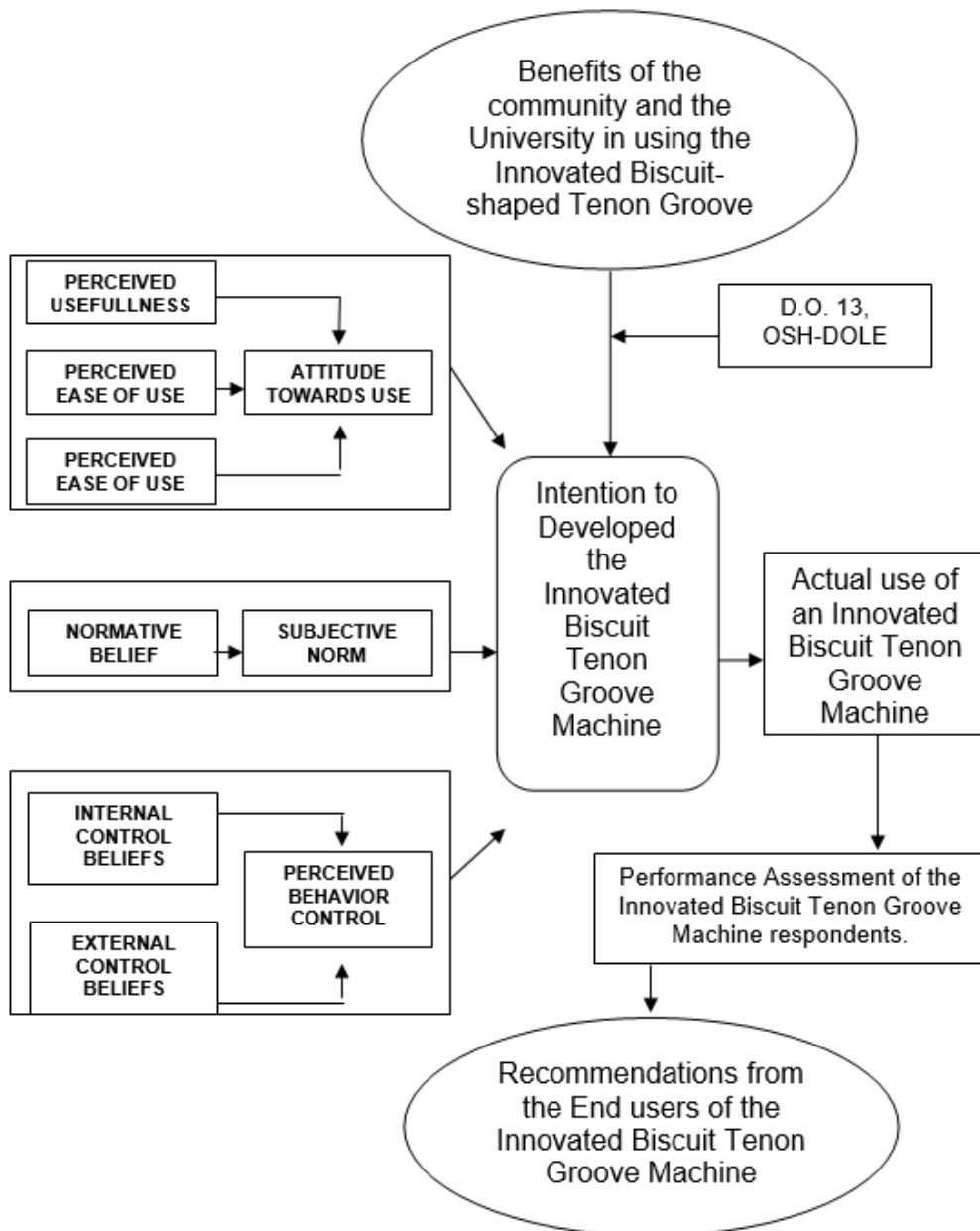

Figure 1. Theoretical and Conceptual Framework of the Study

Intention to develop the Innovated Biscuit Tenon Groove Machine. It refers to a machine that will serve to the need of the program and the university maintenance.

Actual use of an Innovated Biscuit Tenon Groove Machine. It refers to the utilization of the end users in the workplace.

Performance Assessment of the Innovated Biscuit Tenon Groove Machine respondents. It refers the evaluation of the machine as to the given functionality.

Recommendations from the End users of the Innovated Biscuit Tenon Groove Machine. It refer the feedback or suggestions from the end users after the actual demonstration of the machine.

This proposed Innovated Biscuit-shaped Tenon Groove Machine will be using in the production of furniture. It will be the capacity to produce parts and faster. The machine will involve spindle mechanism with belt and hand drill. It includes

implementing accessories such as: drawer rollers, mechanical scissor jacks and metal frameworks.



Figure 1. Proposed Innovated Biscuit Tenon Groove Machine

RESEARCH METHODOLOGY

This study employed a descriptive analysis in order to gather facts relevant in attaining the details in planning, designing, and fabricating the Technology Model of an Innovated Biscuit Tenon Groove Machine. Normative survey is the mode of acquiring data and the questionnaire serve as the main instrument. Quasi-experimental methods particular survey research was utilized on this study. Questionnaires were given to 5 professors/ instructors and 90 students for evaluation. Gathered data will be treated using total weighted points, weighted mean and t-test. The researchers prepared letter of request asking permission to conduct the research study. Ocular inspection and distribution of questionnaires to the campus were collected. Collection of questionnaires, weighing and using of the numerical rating scales were accomplished. After collecting and tallied the data, the researcher collected all comments and suggestions based on the findings and recommendations on what instructional model applied. Furthermore, the researchers adopted and used the illustrated in-process-out flow to enhanced Technology Model Innovated Biscuit Tenon Groove Machine for the use of the whole CTU-Pinamungajan Extension campus specifically the Interior Design Technology trade area. Just to give a sort of background of the school, CTU, where this study held. The Cebu Technological University, is an educational institution located in Cebu City, Philippines. CTU is considered as a Center of Excellence for Technology Education as it is ISO 9001:2008-certified by the Anglo-Japanese-American registrars. It was previously named Cebu State College of Science and Technology and was converted Cebu Technological University through Republic Act 9744 under the governance of President Gloria Macapagal-Arroyo.

The respondents of the study were determined by randomly selected techniques as a requirement for the intended study. Specifically, it included first year and second year Bachelor of Industrial Technology - Interior Design Technology students; Interior Design Technology instructors/ professors of Cebu Technological University - Pinamungajan Extension Campus and the industry experts will be chosen to validate

the acceptability of the Device. They are considered as skilful in their own field. The instruments used in this study were adopted from Developing and Testing Questionnaires/Instruments by Rama B. Radhakrishna, 2007. Questionnaires are the most widely used data collection methods in educational and evaluation research. This article describes the process for developing and testing questionnaires and posits five sequential steps involved in developing and testing a questionnaire: research background, questionnaire conceptualization, format and data analysis, and establishing validity and reliability. Systematic development of questionnaires is a must to reduce many measurement errors. Following these five steps in questionnaire development and testing will enhance data quality and utilization of research and merged with Technology Acceptance Model (TAM). There were three -sets of questionnaires- one for the students, instructors, professors and the selected industry Experts. The questionnaires for the student, instructor and experts have proximity of content. The data gathered from the survey questionnaire will be tallied, collated, tabled and subjected to the statistical treatments of Weighted Mean so as to determine the respondents' perception in the applicability level and the effectiveness of the Technology Model of an Innovated Biscuit-Shaped Tenon Groove Machine. T-test in order to determine the significance among the mean validation on the custom of the Technology Model of an Innovated Biscuit-Shaped Tenon Groove Machine and its performance. Lastly, for the Scoring Procedure, the weighted categories of the average points will be used as the mean item evaluated. Assessment scale will be utilized and to provide response of the acceptability of the Technology Model of an Innovated Biscuit-Shaped Tenon Groove Machine.

DISCUSSION

Randomly selected respondents from Interior Design Technology students, instructors/professors, and industry experts were chosen to validate the Device's acceptability. It has manifested on the table below is the distribution of the respondents with the corresponding size of population and the percentage.

Table 1

Distribution of Respondents N=95

Respondents	Population Size (N)	Percentage (%)
All Second Year BIT Interior Technology students	45	47
All BIT Interior Design Technology instructors	45	47
Selected Industries Experts	5	6
TOTAL	95	100

Based on the documents presented the researchers were developed the innovated device as part of the technology model.

THE PRIOR ARTS RELATED TO BISCUIT GROOVE MACHINE

The relatively complex geometry and loading of the T&G joints precludes reliable analytical modeling of the stresses in the adherents and adhesive. Therefore,

three dimensional finite element models were used to evaluate the stress distribution in the adhesively bonded tongue and-groove joint specimens. The meshes were generated with 8-noded three-dimensional brick elements in the finite element pre- and post-process package MSC/ PATRAN (version 7.5) [16], and the numerical calculations were carried out using ABAQUS program (version 5.8) [17]. Displays of stress distribution in all parts of tongue-and-groove joints were generated with the MSC/PATRAN (Dvorak et al., 2001).

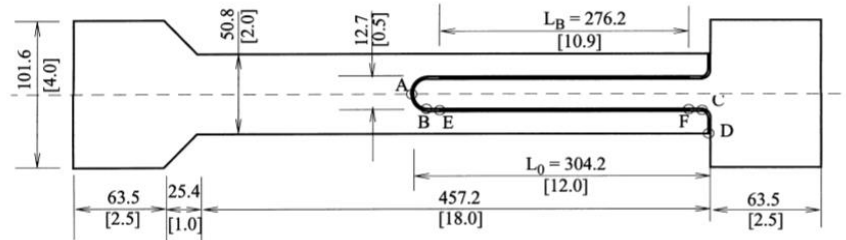
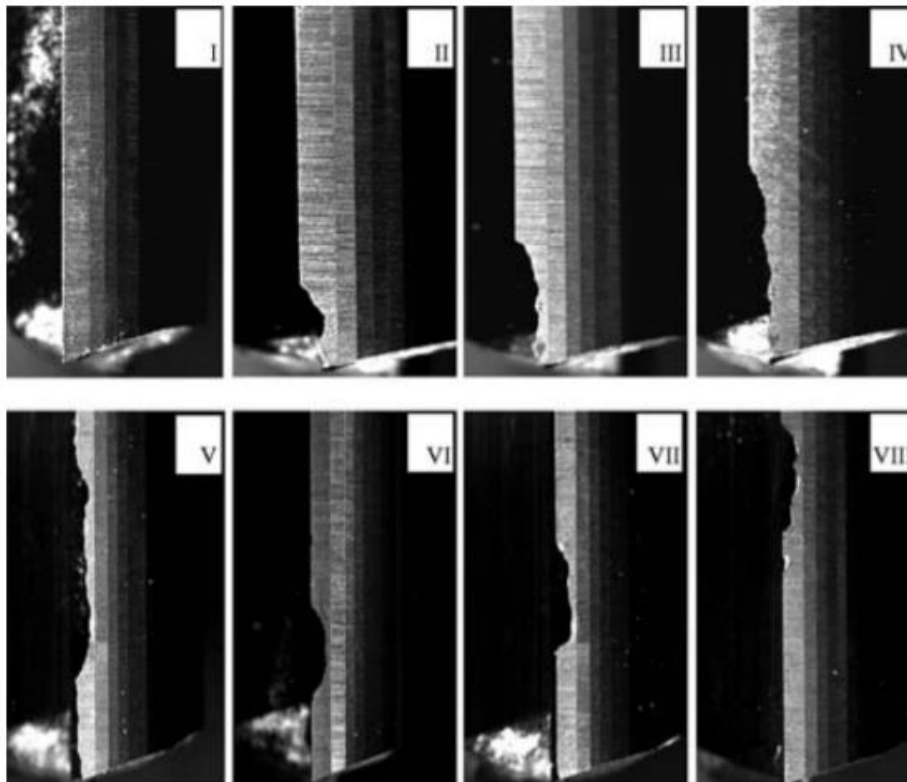
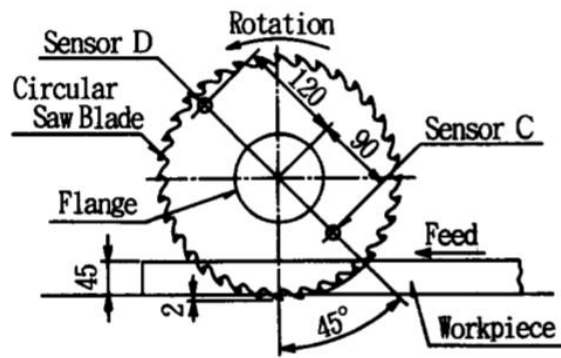

Figure 5. Geometry of the finite element model of bonded test specimen of the T&G joint, consisting of a 12 in. long steel insert and a fitting groove in a woven E-glass/vinyl ester laminate. Similar specimens with 8- and 4-inches long inserts were also analyzed and tested



The automation of wood machining operations requires the continuous and accurate information of the machining process. An effective process monitoring scheme should make the operator alert and/or shut down the machine automatically when a detrimental condition occurs (Zhu, Tanaka, Ohtani & Takimoto, 2004).

Figure 6. Normal and damaged cutting edge of router bits



The experimental relation between natural frequency f_n and slot length L_s is given in Fig. 7, for the circular saw blade at rest with four slots fixed with a 135-mm diameter flange. A frequency up to 1250 Hz is shown here. In the figure, the symbol n indicates the nodal diameter number, and the nodal circle number m is zero in this frequency range. A sign C) indicates the case of even nodal diameter number, and a sign ZX indicates the case of an odd nodal diameter number (Nishio & Marui, 1996).

Figure 7. Cutting apparatus using circular saw blade

TECHNICAL REQUIREMENTS FOR DEVELOPMENT OF AN INTEGRATED PROGRAMMABLE LOGIC CONTROLLED BISCUIT-SHAPED TENON GROOVE DEVICE

The development of an Innovated Biscuit-Shape Tenon Groove Device was composed of Mechanical works, Electrical works, Electronic works, wood works and Pneumatic control Systems. The researcher was analyzing how the machine work fast and safe for the end-users. Trials in experimenting the innovation until it works. The innovated device has various parts such as: motor, mechanical screw jack, drawer slides, mechanical turntable, pumps, electronic converter and pneumatic hoses and switches.

Detailed Device Plan

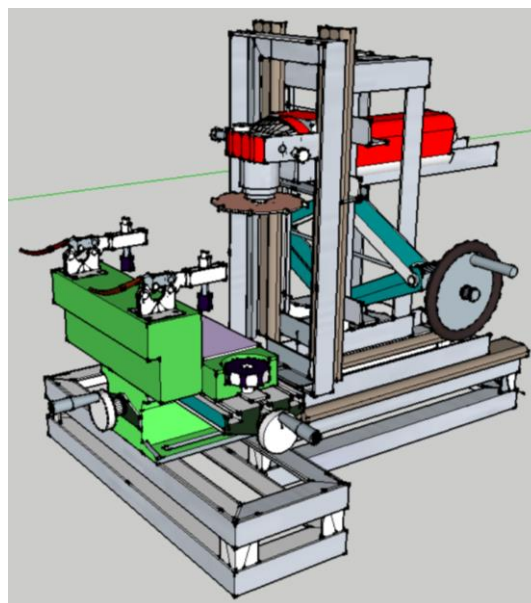

Figure 8. Isometric View

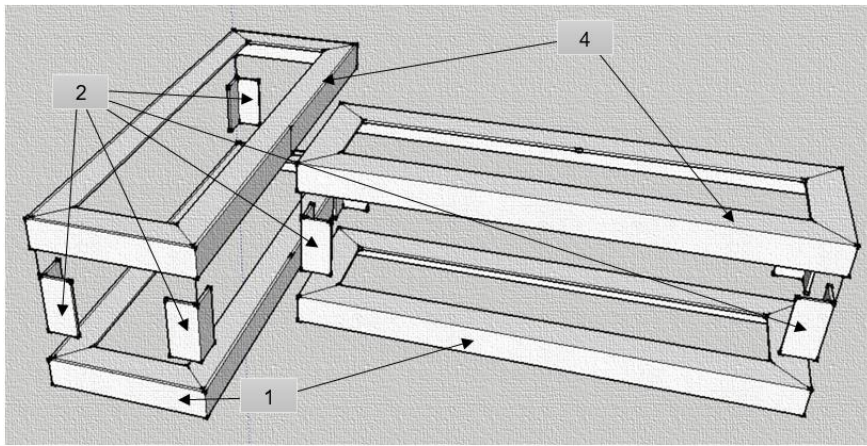

Figure 10. Explode part of device Base Frame

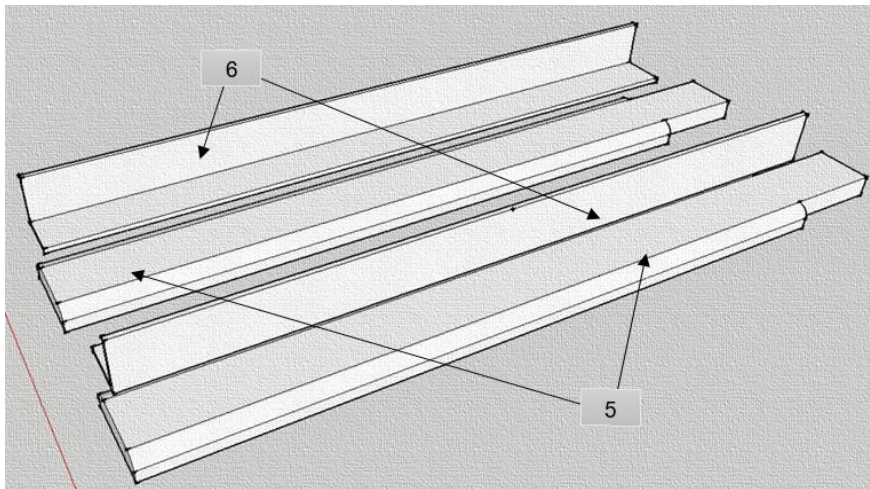

Figure 11. Explode part of device mechanical rollers

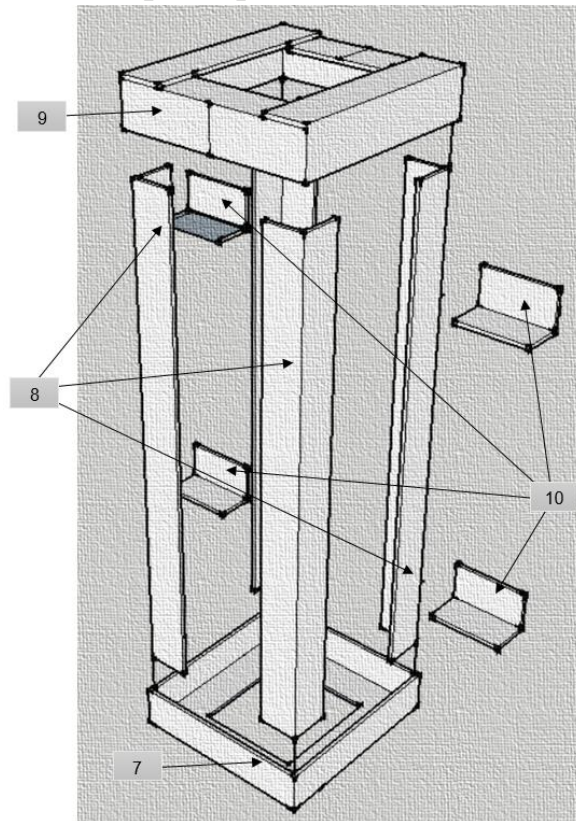

Figure 12. Explode part of device Metal Mast frame

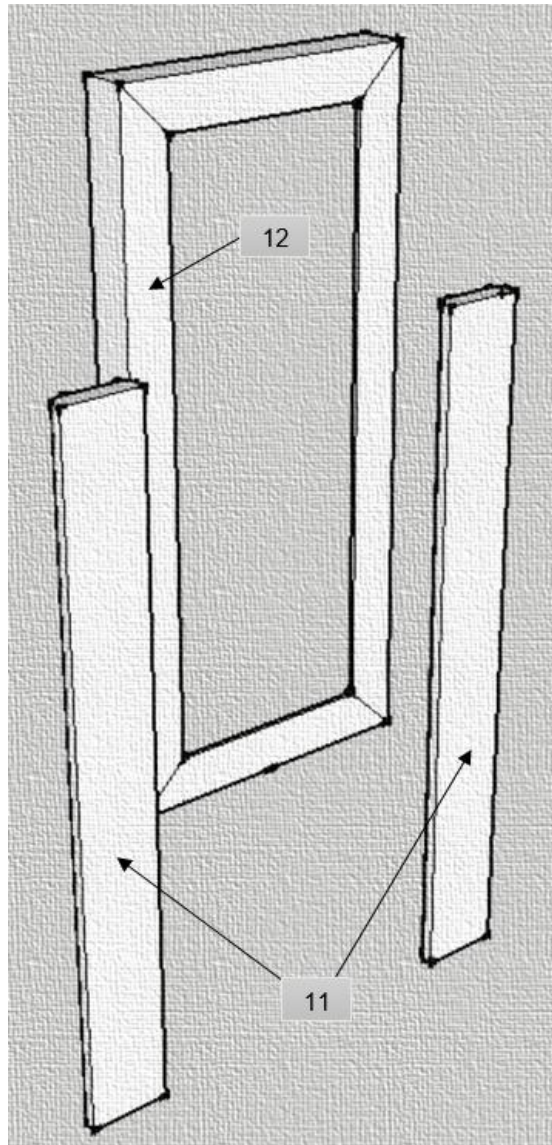

Figure 13. Explode part of device vertical roller sliders

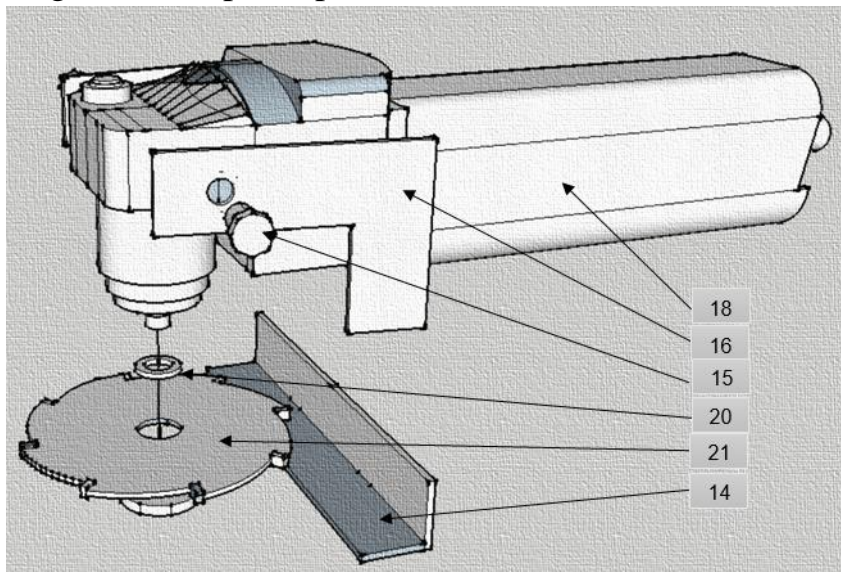

Figure 14. Explode part of device motor grinder

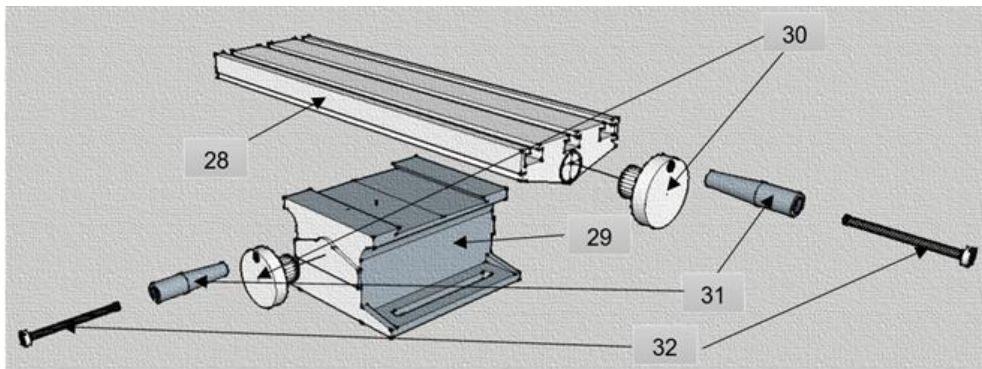

Figure 15. Explode part of device of rotary turntable

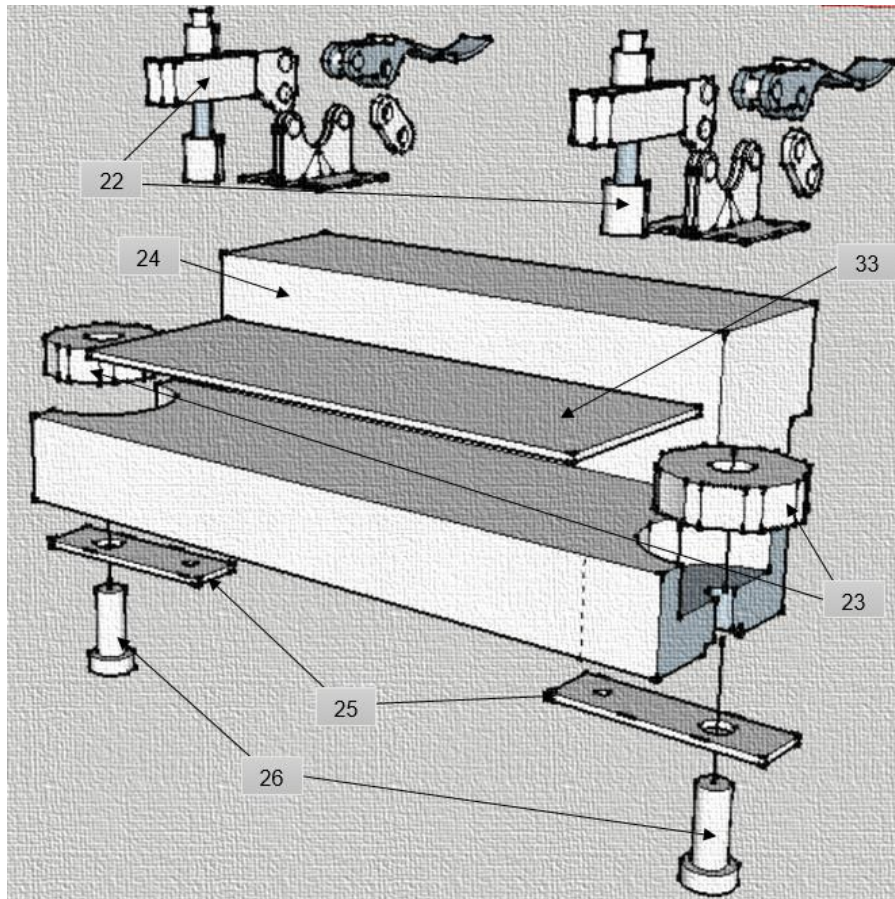

Figure 16. Explode part of device safety jig and clamps

Table 3

Materials Cost

Part	Item/s	Quantity	Unit Price	Amount
A. Mechanical Frame Works				
	Angle Grinder	1 Unit	3,200.00	3,200.00
	Rotary Turntable	1 Unit	3,200.00	3,200.00
	Mechanical Screw Jack	1 Pc	1,200.00	1,200.00
	Wheel Knob	1 Pc	450.00	450.00
	Angle Bar 1"x1"x6.00m	2 Lengths	400.00	800.00
	Mechanical Sliding Rollers	2 Pairs	350.00	700.00
Sub-Total:				9,550.00
B. Electrical and Electronic Works				
	On/off electrical Switch	1 Pc	350.00	350.00
	2 Gang Outlets 220V	1 Pc	120.00	120.00

	Electrical wires number 14	10 meters	200.00	2,000.00
	Power Converter	1 Unit	3,600.00	3,600.00
Sub-Total:				6,070.00
C. Pneumatics Works				
	Air Compressor 12V	1 Unit	2,500.00	2,500.00
	Air Switch	1 Pc	350.00	350.00
	Fittings	1 Lot	1,200.00	1,200.00
	Pneumatics Hose number ¼" diameter	5 Meters	20.00	100.00
Sub-Total:				4,150.00
D. Accessories				
	Welding Rod	2 Kilos	150.00	300.00
	Mechanical bolts and screw	1 Lot	500.00	500.00
	Electrical Tapes	1 Roll	75.00	75.00
	Rivets	1 Lot	300.00	300.00
	Circular Saw Blade # 4" dia.	1 Pc	750.00	750.00
	Soldering Lead	1 Meter	150.00	150.00
	Toggle Clamps	2 Pcs	750.00	1,500.00
	Plastic knobs	1 Pc.	750.00	750.00
	Wood s4s number 2'x4"x8'	1 Length	400.00	400.00
	Wood Glue	1 Liter	75.00	75.00
	Cable Tie	1 Pack	120.00	120.00
	Flat bar 1/8" x 1" x 6.00M	1 Length	250.00	250.00
	Drill Bit 1/8" dia.	5 Pcs.	50.00	250.00
	Cutting Disc 4"	10 Pcs.	45.00	450.00
Sub-Total:				5,870.00
E. Material Cost				25,640.00
F. Labor and Transportation Cost				
	Labor (60%)			15,384.00
	Transportation			2,000.00
Grand Total:				Php 43,024.00

The innovated device has materials involved such as: Mechanical, Electrical, Electronics, Pneumatics and woodworking parts. Based on the quantity survey it has six components that the researcher acquired namely: Mechanical Frameworks has expensed Php 9,550.00; for Electrical and Electronic Works has also expensed 6,070.00; for Pneumatics Works has expensed 4,150.00; for the Accessories has also expensed 5,870.00. Therefore, the total expensed of materials was Php 25,640.00 with labor cost was 15,384.00 and the transportation cost was 2,000.00 and the grand total of the innovated device was Php 43,024.00 only.

Table 4

Safety N=100

Characteristics of Safety of the Device	All Third Year Technology and Engineering students (45)		All BIT Technology and Engineering Professors (45)		Selected Industries Experts (10)	
	(f)	(%)	(f)	(%)	(f)	(%)
<i>Safe to operate the pneumatic system.</i>	44	97.77	44	97.77	10	100
<i>Easy to switches on and off power supply.</i>	43	95.55	43	95.55	10	100

<i>Safe to cut the workpieces by pressing the pneumatic switch and holding the workpieces by using the toggle clamps.</i>	44	97.77	44	97.77	10	100
<i>Average:</i>	43.66	97.03	43.66	97.03	10	100

As indicated in Table 4 Safety of the device. It is shows that there were three(3) Characteristics of Safety of the Device such as: *Safe to operate the pneumatic system, Easy to switches on and off power supply and Safe to cut the workpieces by pressing the pneumatic switch and holding the workpieces by using the toggle clamps.*

Based on the data collected from the selected respondents, there were 44 or 97.77% rated by All Third Year Technology and Engineering students; 44 or 97.77% rated All BIT Technology and Engineering Professors; and 10 or 100% rated by Selected Industries Experts in terms of “*Safe to operate the pneumatic system*”; there were 43 or 95.55% rated by All Third Year Technology and Engineering students; 43 or 95.55% % rated All BIT Technology and Engineering Professors; and 10 or 100% rated by Selected Industries Experts in terms of “*Easy to switches on and off power supply*”; and there were 44 or 97.77% rated by All Third Year Technology and Engineering students; 44 or 97.77% rated All BIT Technology and Engineering Professors; and 10 or 100% rated by Selected Industries Experts in terms of “*Safe to cut the work pieces by pressing the pneumatic switch and holding the work pieces by using the toggle clamps*”. Therefore, the highest scores rated by the respondents was the Selected Industries Experts with the weighted mean of 10 or 100% followed by All Third Year Technology and Engineering students with the scores of 43.66 or 97.03% and All BIT Technology and Engineering Professors with the scores of 43.66 or 97.03%.

The implication of the table was safe after the return demonstration from the selected respondents. The end-users were performed the machine with specific operations using the innovation.

Maintenance

To maintain the performance of the machine, the operator will always follow the routine preventive maintenance and follow procedures during before and after operations.

Table 5

Maintenance N=100

Characteristics of Safety of the Device	All Third Year Technology and Engineering students (45)		All BIT Technology and Engineering Professors (45)		Selected Industries Experts (10)	
	(f)	(%)	(f)	(%)	(f)	(%)
<i>Easy to replace hoses and other pneumatic parts.</i>	44	97.77	44	97.77	10	100
<i>Easy to apply grease to all mechanical rollers and screw</i>	43	95.55	43	95.55	10	100

<i>lifting jack.</i>						
<i>Easy to lubricate all moving parts of the innovated device.</i>	44	97.77	44	97.77	10	100
<i>Average:</i>	43.66	97.03	43.66	97.03	10	100

As indicated in Table 5 Maintenance of the device. It is shows that there were three(3) Characteristics of Maintenance of the Device such as: *Easy to replace hoses and other pneumatic parts, Easy to apply grease to all mechanical rollers and Easy to lubricate all moving parts of the innovated device.*

Based on the data collected from the selected respondents, there were 44 or 97.77% rated by All Third Year Technology and Engineering students; 44 or 97.77% rated All BIT Technology and Engineering Professors; and 10 or 100% rated by Selected Industries Experts in terms of “*Easy to replace hoses and other pneumatic parts*”; there were 43 or 95.55% rated by All Third Year Technology and Engineering students; 43 or 95.55% % rated All BIT Technology and Engineering Professors; and 10 or 100% rated by Selected Industries Experts in terms of “*Easy to apply grease to all mechanical rollers*”; and there were 44 or 97.77% rated by All Third Year Technology and Engineering students; 44 or 97.77% rated All BIT Technology and Engineering Professors; and 10 or 100% rated by Selected Industries Experts in terms of “*Safe to cut the workpieces by pressing the pneumatic switch and holding the workpieces by using the toggle clamps*”. Therefore, the highest scores rated by the respondents was the Selected Industries Experts with the weighted mean of 10 or 100% followed by All Third Year Technology and Engineering students with the scores of 43.66 or 97.03% and All BIT Technology and Engineering Professors with the scores of 43.66 or 97.03% as to “*Easy to lubricate all moving parts of the innovated device*”.

The implication of the table was easy to maintain the device by selected respondents. The end-users were performed the machine with specific operations using the innovation and easy to replace parts and maintenance.

LEVEL OF EFFECTIVENESS BASED ON ITS FUNCTIONALITY OF THE INTEGRATED PROGRAMMABLE LOGIC CONTROLLED BISCUIT-SHAPED TENON GROOVE DEVICE

David A. Garvin, a specialist in the area of quality control, argues that quality can be used in a strategic way to compete effectively and an appropriate quality strategy would take into consideration various important dimensions of quality.

Performance

It involves the various operating characteristics of the device such as: Pneumatic cylinder functions, toggle clamps, rotary turntables, Mechanical Jack movement, the portable grinding machine, mechanical rollers and electrical switches, these characteristics were used during the fabrication of the device.

Table 4

Performance N=100

Characteristics of the device	All Third Year Technology and Engineering students (45)		All BIT Technology and Engineering Professors (45)		Selected Industries Experts (10)	
	Mean	VD	Mean	VD	Mean	VD
Performance is the speed at which the machine or work station runs expressed as a percentage of the speed it is designed to run.	4.88	VHE	4.88	VHE	5.0	VHE
Availability is the asset operating time expressed as a percentage of available operating time.	4.77	VHE	4.77	VHE	5.0	VHE
Quality is the total number of good units produced expressed as a percentage of the total number of units that were started.	5.0	VHE	5.0	VHE	5.0	VHE
<i>Average:</i>	4.88	VHE	4.88	VHE	4.88	VHE
<i>Interpretation:</i>	Very Highly Effective					

Legend:	VHE-	Very Highly Effective	E-	Effective	(f)	Mean
	HE-	Highly Effective	NT-	Not Effective	(%)	Percentage
	ME-	Moderately Effective			VD	Verbal Description

The results on the table were Performance, Availability, Quality of the innovated device was “Very Highly Effective”.

Performance the weighted mean was 4.88 for Technology and Engineering students; 4.88 for the professors and 5.0 for selected industry experts;

Availability the weighted mean was 4.77 for Technology and Engineering students; 4.77 for the professors and 5.0 for selected industry experts;

Quality the weighted mean was 5.00 for Technology and Engineering students; 5.00 for the professors and 5.0 for selected industry experts. The implications of the table about the durability of the innovated device was “Very Highly Effective” due to the structural metal frameworks, stability of the motor and the supply of the air fluid from the air compressor.

Features

These are features that are supplemental to the basic operating features such as: Stability of Metals Fabrication, Machine setup and installation, Pneumatic controlled installation, Mechanical Rollers and screw jack installation.

Table 5

Features N=100

Features of the device	All Third Year Technology and Engineering students (45)		All BIT Technology and Engineering Professors (45)		Selected Industries Experts (10)	
	Mean	VD	Mean	VD	Mean	VD

<i>Stability of Metals Fabrication</i>	4.88	VHE	4.88	VHE	5.00	VHE
<i>Machine setup and installation</i>	4.88	VHE	4.88	VHE	5.00	VHE
<i>Pneumatic controlled installation</i>	4.88	VHE	4.88	VHE	5.00	VHE
<i>Mechanical Rollers and screw jack installation</i>	4.88	VHE	4.88	VHE	5.00	VHE
<i>Overall Weighted Mean:</i>	4.89	VHE	4.89	VHE	5.00	VHE
<i>Interpretation:</i>	Very Highly Effective					

The result on the table were *Stability of Metals Fabrication*, *Machine setup and installation*, *Pneumatic controlled installation* and the *Mechanical Rollers and screw jack installation* of the innovated device was “Very Highly Effective”. *Stability of Metals Fabrication* the weighted mean was 4.88 for Technology and Engineering students; 4.88 for the professors and 5.0 for selected industry experts; *Machine setup and installation* the weighted mean was 4.88 for Technology and Engineering students; 4.88 for the professors and 5.0 for selected industry experts; *Pneumatic controlled installation* the weighted mean was 4.88 for Technology and Engineering students; 4.88 for the professors and 5.0 for selected industry experts; *Mechanical Rollers and screw jack installation* the weighted mean was 4.88 for Technology and Engineering students; 4.88 for the professors and 5.0 for selected industry experts.

The implications of the table about the features of the innovated device were “Very Highly Effective” due to the appropriate functions, easy to use and safety of the device.

Reliability

Reliability of a product is the degree of dependability and trustworthiness of the benefit of the product for a long period of time. It addresses the probability that the product will work without interruption or breaking down.

Table 6

Reliability N=100

Attributes of the device	All Third Year Technology and Engineering students		All BIT Technology and Engineering Professors		Selected Industries Experts	
	Mean	VD	Mean	VD	Mean	VD
<i>Control of Components</i>	4.88	VHE	4.88	VHE	5	VHE
<i>Fabrication Process</i>	4.88	VHE	4.88	VHE	5	VHE
<i>Use</i>	4.88	VHE	4.88	VHE	5	VHE
<i>Overall Weighted Mean:</i>	4.89	VHE	4.89	VHE	5.0	VHE
<i>Interpretation:</i>	Very Highly Effective					

The results on the table were *Control of Components*, *Fabrication Process*, *Use* of the innovated device was “Very Highly Effective”. *Control of Components* the weighted mean was 4.88 for Technology and Engineering students; 4.88 for the professors and 5.0 for selected industry experts; *Fabrication Process* the weighted mean was 4.88 for Technology and Engineering students; 4.88 for the professors and 5.0 for selected industry experts; *Use* the weighted mean were 4.88 for Technology

and Engineering students; 4.88 for the professors and 5.0 for selected industry experts. The implications of the table about the reliability of the innovated device were “Very Highly Effective” due to the structural metal frameworks, stability of the motor and the supply of the air fluid from the air compressor.

Conformance

It is the degree to which the product conforms to pre-established specifications. All quality products are expected to precisely meet the set standards.

Table 7

Conformance N=100

Attributes of the device Conformance	All Third Year Technology and Engineering students (45)		All BIT Technology and Engineering Professors (45)		Selected Industries Experts (10)	
	Mean	VD	Mean	VD	Mean	VD
<i>Quality Control</i>	4.88	VHE	4.88	VHE	5.0	VHE
<i>Quality Assurance</i>	4.77	VHE	4.77	VHE	5.0	VHE
<i>Specifications</i>	4.88	VHE	4.88	VHE	5.0	VHE
<i>Quality</i>	4.88	VHE	4.88	VHE	5.0	VHE
<i>Overall Weighted Mean:</i>	4.852	VHE	4.852	VHE	5.0	VHE
<i>Interpretation:</i>	Very Highly Effective					

The result on the table were quality control, quality Assurance, Specifications and the quality of the innovated device was “Very Highly Effective”. Quality Control the weighted mean were 4.88 for Technology and Engineering students; 4.88 for the professors and 5.0 for selected industry experts; Quality Assurance the weighted mean were 4.77 for Technology and Engineering students; 4.77 for the professors and 5.0 for selected industry experts; Specifications the weighted mean were 4.88 for Technology and Engineering students; 4.88 for the professors and 5.0 for selected industry experts; Quality the weighted mean were 4.88 for Technology and Engineering students; 4.88 for the professors and 5.0 for selected industry experts. The implications of the table about the conformance of the innovated device was “Very Highly Effective” due to the appropriate functions, easy to use and safety of the device.

Durability

It measures the length of time that a product performs before a replacement becomes necessary. The durability of the device can range from 3 to 5 years.

Table 8

Durability N=100

Attributes of the device	All Third Year Technology and Engineering students (45)		All BIT Technology and Engineering Professors (45)		Selected Industries Experts (10)	
	Mean	VD	Mean	VD	Mean	VD
<i>Vibration Testing. is generally conducted out on the production floor or within a</i>	4.77	VHE	4.77	VHE	5.0	VHE

<i>laboratory setting.</i>						
<i>Ageing Testing. Uses sped up conditions to advance the ageing process to test the product to its limits. The testing is usually carried out in a laboratory setting where the sped-up conditions and continuous stress imposed on the product will determine its lifespan.</i>	4.88	VHE	4.88	VHE	5.0	VHE
<i>Fatigue Testing. Assessed how a product degrades over time. This test sets out to add force to the product for a repeated number of times until the product breaks. This produces the result of how long the product should last under strenuous conditions. The testing machine is a table top machine that creates the simulated motion in rapid progression to replicate a fatigued condition.</i>	4.77	VHE	4.77	VHE	5.0	VHE
<i>Overall Weighted Mean:</i>	4.81	VHE	4.81	VHE	5.0	VHE
<i>Interpretation:</i>	Very Highly Effective					

The results on the table were Vibration Testing, *Ageing Testing*, *Fatigue Testing* of the innovated device was “Very Highly Effective”. Vibration Testing the weighted mean were 4.77 for Technology and Engineering students; 4.77 for the professors and 5.0 for selected industry experts; *Ageing Testing* the weighted mean were 4.88 for Technology and Engineering students; 4.88 for the professors and 5.0 for selected industry experts; *Fatigue Testing* the weighted mean were 4.77 for Technology and Engineering students; 4.77 for the professors and 5.0 for selected industry experts. The implications of the table about the durability of the innovated device was “Very Highly Effective” due to the structural metal frameworks, stability of the motor and the supply of the air fluid from the air compressor.

Serviceability

It refers to the timekeeping, politeness, ability and comfort in repair when the product breakdowns and is showed for repairs. Before the machine start, let us make it clear, EVERY time a cutting wheel blade is mounted or remounted onto a machine the operator must check the wheel and machine's speed to make sure the wheel is not operated in an over-speed condition. The cutting wheel's safe operating speed in marked on the wheel and the machine's normal operating speed is marked on the machine. NEVER exceed the cutting wheel's safe operating speed as stated in Revolutions Per Minute (RPM) or in Surface Feet Per Minute (SFPM). Failure to comply with this requirement is not only very dangerous, but is also a violation of ANSI safety requirements and OSHA law.

Table 9

Serviceability N=100

Attributes of the device Serviceability	All Third Year Technology and Engineering students	All BIT Technology and Engineering Professors	Selected Industries Experts
---	--	---	-----------------------------

	(45)		(45)		(10)	
	Mean	VD	Mean	VD	Mean	VD
<i>Pneumatic controlled components must check before, during and after operations.</i>	4.77	VHE	4.77	VHE	5.0	VHE
<i>Rollers and screw jack must apply grease and oil every end of the week as part of the maintenance schedule.</i>	4.88	VHE	4.88	VHE	5.0	VHE
<i>The cutting wheels must check before the operations.</i>	4.77	VHE	4.77	VHE	5.0	VHE
<i>Overall Weighted Mean:</i>	4.81	VHE	4.81	VHE	5.0	VHE
<i>Interpretation:</i>	Very Highly Effective					

The results on the table were *Pneumatic controlled components must check before, during and after operations, Rollers and screw jack must apply grease and oil every end of the week as part of the maintenance schedule, The cutting wheels must check before the operations.*

Pneumatic controlled components must check before, during and after operations the weighted mean were 4.77 for Technology and Engineering students; 4.77 for the professors and 5.0 for selected industry experts; *Rollers and screw jack must apply grease and oil every end of the week as part of the maintenance schedule* the weighted mean were 4.88 for Technology and Engineering students; 4.88 for the professors and 5.0 for selected industry experts; *The cutting wheels must check before the operations* the weighted mean were 4.77 for Technology and Engineering students; 4.77 for the professors and 5.0 for selected industry experts.

The implications of the table about the device serviceability of the innovated device was “Very Highly Effective” due to the availability of the spare parts of the local market.

Aesthetics

Aesthetic aspect of a product is comparatively subjective in nature and refers to its impact on the human senses such as how it looks, feels, sounds, tastes and so on, depending upon the type of product. Automobile companies make sure that in addition to functional quality, the automobiles are also artistically attractive.

Table 10

Aesthetics N=100

Attributes of the device	All Third Year Technology and Engineering students (45)		All BIT Technology and Engineering Professors (45)		Selected Industries Experts (10)	
	Mean	VD	Mean	VD	Mean	VD
<i>Measuring maximum/minimum dimensions of parts or products.</i>	4.77	VHE	4.77	VHE	5.0	VHE
<i>Measuring roundness or angle of the tips of metal parts.</i>	4.88	VHE	4.88	VHE	5.0	VHE

<i>Measuring positions of machine, edges and labels.</i>	4.77	VHE	4.77	VHE	5.0	VHE
<i>Measuring widths of sheet/film products.</i>	4.88	VHE	4.88	VHE	5.0	VHE
<i>Overall Weighted Mean:</i>	4.825	VHE	4.825	VHE	5.0	VHE
<i>Interpretation:</i>	Very Highly Effective					

The result on the table were *Measuring maximum/minimum dimensions of parts or products, Measuring roundness or angle of the tips of metal parts, Measuring positions of machine, edges and labels* and the *Measuring widths of sheet/film products* was “Very Highly Effective”. *Measuring maximum/minimum dimensions of parts or products* the weighted mean were 4.77 for Technology and Engineering students; 4.77 for the professors and 5.0 for selected industry experts;

Measuring roundness or angle of the tips of metal parts the weighted mean were 4.88 for Technology and Engineering students; 4.88 for the professors and 5.0 for selected industry experts; *Measuring positions of machine, edges and labels* the weighted mean were 4.77 for Technology and Engineering students; 4.77 for the professors and 5.0 for selected industry experts; *Measuring widths of sheet/film products* the weighted mean were 4.88 for Technology and Engineering students; 4.88 for the professors and 5.0 for selected industry experts. The implications of the table about the Aesthetics of the innovated device was “ Very Highly Effective” due to the appropriate drawing details, exploded drawing parts from bottom metal frames to pneumatic systems.

Perceived Quality

Automation helps to increase available working hours as machinery is not dependent upon an operator for it to keep producing products. Quality can be improved by using vision inspection throughout your production process. Vision inspection during the production process enables you to identify and eliminate faulty products earlier in the process. Existence a quality conscious, emphasis on maintaining our quality standards. Assured that necessary quality checks are performed at vendors’ end before acquiring the product. Apart from this, we also run internal quality inspection to ascertain the quality of the product.

Table 11

Perceived Quality N=100

Perceived Quality of the device	All Third Year Technology and Engineering students (45)		All BIT Technology and Engineering Professors (45)		Selected Industries Experts (10)	
	Mean	VD	Mean	VD	Mean	VD
<i>Energy efficiency</i>	4.77	VHE	4.77	VHE	5.0	VHE
<i>Wear & tear degree</i>	4.66	VHE	4.66	VHE	5.0	VHE
<i>Regression</i>	4.66	VHE	4.66	VHE	5.0	VHE
<i>Operational efficiency</i>	4.77	VHE	4.77	VHE	5.0	VHE

<i>Ergonomics</i>	4.66	VHE	4.66	VHE	5.0	VHE
<i>Calibration</i>	4.66	VHE	4.66	VHE	5.0	VHE
<i>Design compliance</i>	4.88	VHE	4.88	VHE	5.0	VHE
<i>Noise level</i>	4.66	VHE	4.66	VHE	5.0	VHE
<i>Alignment & balancing</i>	4.88	VHE	4.88	VHE	5.0	VHE
<i>Overall Weighted Mean:</i>	42.6	VHE	42.6	VHE	5.0	VHE
<i>Interpretation:</i>	Very Highly Effective					

The results on the table were Energy efficiency, Wear & tear degree, Regression, Operational efficiency, Ergonomics, Calibration, Design compliance, Noise level, Alignment & balancing.

Energy efficiency of the innovated device was “Very Highly Effective” the weighted mean was 4.77 for Technology and Engineering students; 4.77 for the professors and 5.0;

Wear & tear degree of the innovated device was “Very Highly Effective” the weighted mean were 4.66 for Technology and Engineering students; 4.66 for the professors and 5.0;

Regression of the innovated device was “Very Highly Effective” the weighted mean was 4.66 for Technology and Engineering students; 4.66 for the professors and 5.0;

Operational efficiency of the innovated device was “Very Highly Effective” the weighted mean was 4.77 for Technology and Engineering students; 4.77 for the professors and 5.0;

Ergonomics of the innovated device was “Very Highly Effective” the weighted mean was 4.66 for Technology and Engineering students; 4.66 for the professors and 5.0;

Calibration of the innovated device was “Very Highly Effective” the weighted mean was 4.66 for Technology and Engineering students; 4.66 for the professors and 5.0;

Design compliance of the innovated device was “Very Highly Effective” the weighted mean was 4.88 for Technology and Engineering students; 4.88 for the professors and 5.0;

Noise level of the innovated device was “Very Highly Effective” the weighted mean was 4.66 for Technology and Engineering students; 4.66 for the professors and 5.0;

Alignment & balancing of the innovated device was “Very Highly Effective” the weighted mean was 4.88 for Technology and Engineering students; 4.88 for the professors and 5.0;

The implications of the table about the perceived quality of the innovated device were “Very Highly Effective” due to the structural metal frameworks, stability of the motor and the supply of the air fluid from the air compressor and fast production.

LEVEL OF ACCEPTABILITY BASED ON DIMENSIONS OF QUALITY

The acceptability of an innovated biscuit device was based on the dimensions of quality. The respondent-groups instructed before the demonstration of device by rating using quality of dimensions. The researcher was explained and illustrated the functions of the device prior the demonstrations.

Table 12

Level of Acceptability N=100

Attributes of the device	All Third Year Technology and Engineering students (45)		All BIT Technology and Engineering Professors (45)		Selected Industries Experts (10)	
	Mean	VD	Mean	VD	Mean	VD
<i>Performance</i>	4.88	VHE	4.88	VHE	4.88	VHE
<i>Features</i>	4.89	VHE	4.89	VHE	5.00	VHE
<i>Reliability</i>	4.89	VHE	4.89	VHE	5.0	VHE
<i>Conformance</i>	4.852	VHE	4.852	VHE	5.0	VHE
<i>Durability</i>	4.81	VHE	4.81	VHE	5.0	VHE
<i>Serviceability</i>	4.81	VHE	4.81	VHE	5.0	VHE
<i>Aesthetics</i>	4.825	VHE	4.825	VHE	5.0	VHE
<i>Perceived quality</i>	4.26	VHE	4.26	VHE	5.0	VHE
<i>Overall Weighted Mean:</i>	3.758					
<i>Interpretation:</i>	HE-Highly Acceptable					

Legend:	VHA-	Very Highly Acceptable	A-	Acceptable	(f)	Mean
	HA-	Highly Acceptable	NA-	Not Acceptable	(%)	Percentage
	MA-	Moderately Acceptable			VD	Verbal Description

The results of an innovated device based on the level of acceptability was rated 3.758 as overall weighted mean. *Performance* 4.88 as rated by engineering and technology students, 4.88 as rated by engineering and technology professors and 4.88 as rated by selected industry experts; *Features* 4.89 as rated by engineering and technology students, 4.89 as rated by engineering and technology professors and 5.00 as rated by selected industry experts; *Reliability* 4.89 as rated by engineering and technology students, 4.89 as rated by engineering and technology professors and 5.00 as rated by selected industry experts; *Conformance* 4.852 as rated by engineering and technology students, 4.852 as rated by engineering and technology professors and 5.00 as rated by selected industry experts; *Durability* 4.81 as rated by engineering and technology students, 4.81 as rated by engineering and technology professors and 5.00 as rated by selected industry experts; *Serviceability* 4.81 as rated by engineering and technology students, 4.81 as rated by engineering and technology professors and 5.00 as rated by selected industry experts; *Aesthetics* 4.852 as rated by engineering and technology students, 4.852 as rated by engineering and technology professors and 5.00 as rated by selected industry experts; and *Perceived quality* 4.26 as rated by engineering and technology students, 4.26 as rated by engineering and technology professors and 5.00 as rated by selected industry experts.

The implications of the innovated device were to adopt and produce for production and for utility model and instruction in the university and the interpretation was "HIGHLY ACCEPTABLE".

SUMMARY

The main purpose of the study is to determine the effectiveness and acceptability of an Innovated biscuit-shaped groove machine for wood lamination using quality dimensions. The study was to integrate the competencies such as: mechatronics and programmable logics control. The study was to perform the mechanism of mechanical, pneumatics and other accessories in order to perform forward, reverse and cut the circular cutting of wood to create grooves.

FINDINGS

The result showed that the subject of the study was determined by purposive sampling method as a requirement for the intended study. Specifically, the technology and engineering students at Cebu Technological University-Pinamungajan Campus as major part of the technology and engineering programs.

CONCLUSION

Based on the findings and after a thorough yet careful analysis and interpretation of the research study, it is concluded that the imperative usage of this Innovated Biscuit-Shaped Groove Machine meets the required standards and is precise guide in Campus Maintenance System and for technology instruction.

RECOMMENDATION

It is recommended that the Innovated Biscuit-shaped Tenon Groove Machine towards Technology Model for Interior Design Technology Program in Technical Education be adopted and practice for maintenance personnel and for technology and engineering laboratory.

References

Arcadio, R. et al, (2019). Acceptability Testing and Development of a Novel Wood Lathe Balance Rest. Available from Published URL: <http://www.amtm.putpozn.pl> Arch. Mech. Tech. Mater. Vol. 39, (2019) 59-65.

Arcadio, R. et al, (2020). An instructional Model for Designing Innovated Portable Table Router. Available from Published URL: <http://www.jetir.org/view?paper-JETIR200817> Volume 7 / Issue 8 / 2020-08-06.

Broun, J. (2018). Encyclopedia of Woodworking Techniques. Search Press Limited.

Davis, F. D. (1989). Perceived usefulness, perceived ease of use, and user acceptance of information technology. MIS quarterly, 319-340.

Davis, F. D. (1993). User acceptance of information technology: system characteristics, user perceptions and behavioral impacts. *International journal of man-machine studies*, 38(3), 475-487.

Davis, F. D., Bagozzi, R. P., & Warshaw, P. R. (1989). User acceptance of computer technology: A comparison of two theoretical models. *Management science*, 35(8), 982-1003.

Davis, F. D., & Venkatesh, V. (2004). Toward preprototype user acceptance testing of new information systems: implications for software project management. *IEEE Transactions on Engineering management*, 51(1), 31-46.

Dvorak, G. J., Zhang, J., & Canyurt, O. (2001). Adhesive tongue-and-groove joints for thick composite laminates. *Composites science and technology*, 61(8), 1123-1142.

Gibson, Jeremy (1992). Device for mortise, tenon and dovetail joinery. Available from <https://patents.google.com/patent/US5285832A/en>

Hinch, Anthony (2002). Mortiser. Available from <https://patents.google.com/patent/US20020177388A1/en>

Kaplinsky, R., Morris, M., & Readman, J. (2002). The globalization of product markets and immiserizing growth: lessons from the South African furniture industry. *World development*, 30(7), 1159-1177.

Muellers, John (1989). Dovetail machine. Available from <https://patents.google.com/patent/US4031931A/en>.

Nishio, S., & Marui, E. (1996). Effects of slots on the lateral vibration of a circular saw blade. *International Journal of Machine Tools and Manufacture*, 36(7), 771-787.

Radhakrishna, R. B. (2007). Tips for developing and testing questionnaires/instruments. *The Journal of Extension*, 45(1), 25.

Shibata, Yoshinori (1991). Biscuit Jointer. US5273091A United States. Available from <https://patents.google.com/patent/US5273091A/en>.

Venkatesh, V., Thong, J. Y., & Xu, X. (2012). Consumer acceptance and use of information technology: extending the unified theory of acceptance and use of technology. *MIS quarterly*, 157-178.

Yousafzai, S. Y., Foxall, G. R., & Pallister, J. G. (2010). Explaining internet banking behavior: theory of reasoned action, theory of planned behavior, or technology acceptance model?. *Journal of applied social psychology*, 40(5), 1172-1202.

Zhu, N., Tanaka, C., Ohtani, T., & Takimoto, Y. (2004). Automatic detection of a damaged router bit during cutting. *European Journal of Wood and Wood Products*, 62(2), 126-130.